

Questionary DMV / SMV Pigging System



1. Customer

Company _____

Contact / Name _____

Street _____

Post code / City _____

Country _____

Tel. / Fax / Email _____

2. Specification

Product / Media _____

Standard / Size DIN Inch SMS Size: _____

Pipe length _____ m

Pushing media Air Water Other: _____

Cleaning option CIP Yes No
SIP Yes No

Operation manual pneumatic

Pigging rate 1-9 times / day more than 10 times / day

3. Pigging technology

DMV Pigging system One-Way (for low germ processes) 

Single Loop 

Double Loop 

Ring System 

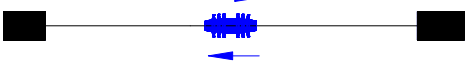
SMV System (for insensitive media) Bi-directional 

4. For detailed quotation, please attach a flow scheme (dxf and pdf preferred).